

---

# The Phrasal Verb in English

*Written By*  
*Mahmoud Al - Qudah*  
*Mahmoud Kanakri*  
*1995*

---

## ABSTRACT

This paper concentrates on the syntactic structure of the phrasal verb and presents eight tests to isolate this verbal structure from other non - phrasal verbal combinations. The tests are usefully channelled to express themselves in regularities underlying phrasal and non - phrasal verbs. It highlights some severe collocational restrictions that obtain with the phrasal structure whose particle is unequivocally realized as an adverbial. The paper also maintains that between and within phrasal and non-phrasal structures are varying degrees of idiomaticity, distinguishing, the most idiomatic (ie the least transparent) structure from the least idiomatic (ie the most transparent) one. It enunciates that although some verbs appear to be of one category than another, there is a continual process of idiomatic ascent that eventually converts 'marginal' and non-phrasal verbs into phrasal ones.

---

## الخلاصة

يركز البحث على البنية النحوية للفعل المركب (Phrasal Verb)، ويقدم ثمانية اختيارات لافراد هذا التركيب الفعلي من التركيبات الفعلية غير المركبة. وقد سبقت الاختبارات، على نحو مفيد، للتعبير عن نفسها فيما ينتظمها مما يؤسس الافعال المركبة، وغير المركبة، ويؤكد البحث ما يرتصف من تقييدات شديدة تحصل، والتركيب المركب، الذي تتحقق اداته، على نحو قاطع، بوصفها ظرفا. ويؤكد البحث، أيضا انه بين البنية المركبة وغير المركبة هناك درجات متباينه تبين البنية الاكثر درجة من حيث التركيب (= الاقل شفافية)، من البنية الاقل درجة من حيث التركيب (= الاكثر شفافية). كما يوضح البحث انه على الرغم من ان بعض الافعال تظهر في كونها من هذا الصنف لا من ذاك، الا ان هناك عملية مستمرة للسموق التركيبي تحول، اخيرا، الافعال الهامشية، والافعال غير المركبة إلى افعال مركبة.

### 1. Introduction

Phrasal verbs are constructions that are formed of a verb plus a particle<sup>(1)</sup> functioning as an adverbial. Two types of phrasal verbs may be distinguished: transitive and intransitive:

(1) He gave up his claim. (transitive phrasal verb)

(2) He gave up. (intransitive phrasal verb)

The transitive phrasal verb is followed by a noun phrase whereas the intransitive phrasal verb is not followed by a noun phrase. This is obvious in sentences (1) and (2) above. However, some verb + adverbial particle combinations which are intransitive also seem to belong to the class of phrasal verbs:

---

(1) Strangely enough, Fabb (1994: 58) suggests that phrasal verbs are verbs that are associated with a prepositional phrase headed by a particular preposition. However, phrasal verbs are syntactically treated as subclass of single verbs. (See Takami, P. 91)

- 
- (3) She turned over.
  - (4) The bridge blew up.
  - (5) Caesar brought up his downfall.

The intransitive verbal forms in these sentences can be related to phrasal verbs in terms of a) understood object b) active form, and c) transitivity (through using a lexeme):

- (6) She turned over the page.
- (7) They blew up the bridge.
- (8) His downfall came about.

Palmer sees these two corresponding forms (intransitive and transitive phrasal verbs) as being respectively semantically passive and semantically active constructions involving the use of different lexemes.<sup>(2)</sup> However, we need to distinguish between a transitive phrasal verb (v + adverbial particle) and the combination of verb + an adverbial:

- (9) The climbers pulled the rope up.
- (10) The climbers pulled the rope upwards.

The two verbal constructions may be distinguished by the possible occurrence of the adverbial with a phrasal verb construction before the NP and its non-occurrence with a combination of a verb + an adverbial. The test which is not an absolute one works well with the phrasal verb but fails with the non-phrasal one:

---

(2) Palmer, P. 224.

---

(11) The climbers pulled up the rope.

(12) The climbers pulled upwards the rope.

The test, however, fails with certain idiomatic constructions:

(13) The climbers pulled up the rope.

(14) The lover cried out his heart.

A further type of phrasal verb has the form of verb plus adjective. The collocation, a close one, behaves syntactically like a phrasal verb:

(15) They pushed the door open.

Palmer suggests that the semantics of both verb and adjective determine the occurrence of the particular adjective in this syntactic position<sup>(3)</sup>:

(16) They packed tight the wadding.

(17) They packed loose the wadding.

The non-acceptability of the second construction obviously relates to the semantics of the particle of the phrasal verb which involves resultant condition and, more specifically, completeness. We need to pack tight. Packing loose fails to substantiate a task that is intended to be complete.

We also have to distinguish between phrasal verb and a prepositional one which forms a much closer combination than verb + prepositional phrase. Palmer cites the following

---

(3) Palmer, P. 223.

---

sentences to distinguish the trio types<sup>(4)</sup>:

(18) The pilot flew in the plane. (phrasal verb)

(19) The sparrow flew in the plane. (prepositional verb)

(20) The passenger flew in the plane. (verb + prep. phrase)

Prepositional verbs may be treated as a special class on the ground of their semantics: motion or a sense of direction and a point of termination, the first feature being a characteristic of the verb, the second a characteristic of the preposition<sup>(5)</sup> whose meaning is similar to that of the adverbial particle of the phrasal verb:

(21) He ran up the hill.

The act of motion substantiated by running is envisaged in relation to the hill and the terminating point the hill.

with a sentence like:

(22) She looked after her son.

Greenbaum and Quirk suggest two complementary

---

(4) Palmer, p. 229.

(5) In recent years preposition stranding has attracted much attention. Takami (1992), in fact, has written a Ph.D. thesis on this issue. The value of this syntactic device stems from the fact that it realizes acceptable strings. Quirk et al. suggest the obligatory cases where prepositions must be deferred. These cases include:

1. passive: Has the room been paid for?
2. infinitival clause with thematization of the prep. complement: He's impossible to work with.
3. ing clauses with thematization: He's worth listening to.' (p. 664)

---

analyses<sup>(6)</sup>

Analysis 1: S                    V                    A (Adjunct)

                  She            looked after       her son

Analysis 2: S                    V                    O

We also have to distinguish between a phrasal verb and a phrasal-prepositional verb. Here, the verbal combination consists of verb plus two particles, respectively, an adverbial and a preposition. The phrasal-prepositional verb forms a unity in the sense of the non-separability of its components and in the sense of its occurrence in passivisation as an entirely close unit:

(23) The wife with whom he cannot put up.

(Such a string is only acceptable as a humorous utterance).  
The verb passes the test of passivisation:

(24) The wife cannot be put up with.

In contrast, the phrasal verb + preposition fails the latter test:

(25) She walked up with her young friend.

(26) \* Her young friend was walked up with.

However, with some phrasal-prepositional verbs, such as fob off with (= get a person to accept something of little or no value by deceit or trickery) the test seems to work well with the

---

(6) Greenbaum and Quirk, p. 339

---

first NP:

(27) She fobbed him off with promises.

(28) He was fobbed off with promises.

Wekker and Hageman are aware that phrasal-prepositional verbs may undergo passivization:<sup>(7)</sup>

(29) We have put up with Helen's frivolous attempts too long.

(30) Helen's frivolous attempts have been put up with too long.

if we examine the VP of (29), we will see that it has the following structure:

(31)

In systemic grammar, a sentence like:

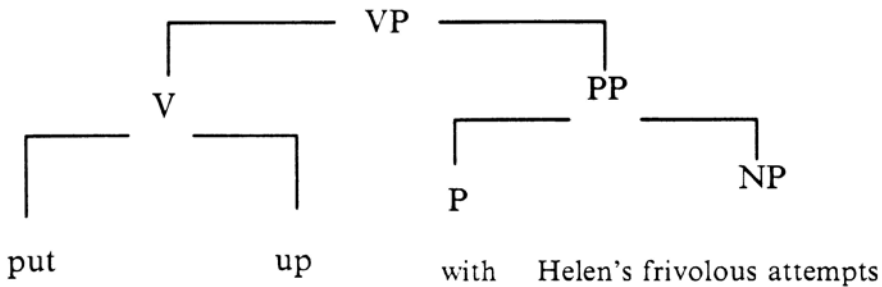

(32) The race got off to a good start.<sup>(8)</sup>

may be analyzed as:

---

(7) Wekker and Haegeman, P. 186.

(8) Freeborn, P. 138

---

S	P pt	Ca
The race	got off	to a good start.

(where S stands for Actor as subject, P. Process as Predicator and Ca adverbial as Complement. (pt) is a label for the adverbial particle).

## II. THE PHRASAL VERB

With phrasal verbs, fairly restricted particles (down, in, off, on, out, up, etc....) tend to occur with fairly restricted verbs (put, take, get, give, make, etc....).<sup>(9)</sup> These severe collocational restrictions may be exemplified by citing that we can **make up a story** but **make down a story** is not possible. Conversely, *He ran up a hill* can be changed to *'He ran down a hill'*.

The following features obtain with phrasal verbs:

- a) The elements of a phrasal verb form a semantic unit (e.g. make up). It is usually possible to find another word to substitute<sup>(10)</sup> for this unit (e.g. 'invent'). In contrast, a non-phrasal structure usually consists of parts that retain their individual meanings.

---

(9) Not all these verbs occur with particles: e.g. take pride in, see fit, put paid to. For more see Quirk et al., p. 1151.

(10) Quirk et al. (1992: 1162), however, question the validity of semantic substitution in the sense of its non-reliability. They offer two reasons in this respect: "First, there are some phrasal verbs that do not have one-word paraphrases, These verbs include 'get away', 'run out of' (The latter is usually categorized as a prepositional-phrasal verb). Second, there are non-idiomatic combinations, such as 'go across', 'go past' and 'sail around', which do not have such paraphrases.



---

b) The particle of a phrasal verb can often go to the end of a clause (e.g. 'He ran a bill up' but \*'He ran a hill up').

c) Where the object is a pronoun, it must precede the particle:

(33) He made it up.

(34) \*He made up it.

d) The particle cannot move with WH:

(35) This is the story which he made up.

(36) \* This is the story up which he made.

e) Phrasal verbs can easily be passivised:

(37) She made up the story.

(38) The story was made up.

f) Phrasal verbs cannot be split by an adverbial:

(39) \*He made quickly up a story.

but:

(40) He ran quickly up a hill.

g) The particle cannot be placed in initial position:<sup>(11)</sup>

(41) \*Up he made a story.

---

(11) Greenbaum and Quirk call this process 'syntactic signs of cohesion,' Greenbaum and Quirk, p. 337

---

(42) Up the hill he ran.<sup>(12)</sup>

h) Nuclear stress falls on the particle of a phrasal verb:

(43) That is the story I made ūp.

(44) \*That is the story I māde up.

(45) This is the hill I rān up.<sup>(13)</sup>

To decide whether a combination of verb + particle is a phrasal verb or not can be established by these tests<sup>(14)</sup>. Note that the answer to the combination a semantic unit?

1. Is the combination a semantic unit?
2. Can particle movement apply?

---

(12) svartvik perceptively expresses the distinction between phrasal verbs and prepositional ones by saying that 'the particle component of a phrasal verb has two fold positional privilege in that it often takes either pronominal or postnominal position, whereas it is restricted to pronominal position (in prepositional verbs.' Svartvik, p. 20

(13) Stress is not a reliable test for polysyllabic prepositions (without, across, over, etc...) for they usually receive stress.

(14) In his Ph. D. thesis, Takami (1992: 91), a Japanese, adds two tests to the battery of the tests stated above. These tests are:

1. Phrasal verbs can be gapped, prepositional verbs cannot:

e. g. John took off his coat and Mary [ ] her hat.

\* John laughed at mary, and Mike [ ] Sue.

2. Phrasal verbs cannot be the focus of a cleft sentence, prepositional verbs can be:

e. g. \* It was on the TV that John switched.

It was on Mary that John relied.

The problem of these additional tests is that they pose more problems and complicate the issue at hand.

---

(make up a story/make a story up<sup>(15)</sup>, but ran up a hill/\* run a hill up)

3. Does the particle obligatorily follow an object pronoun?

(\* made up it)

4. Is it true that the particle cannot move with wh?

(\* The story up which he made/The hill up which he ran)

5. Is it true that an adverb cannot be inserted?

(\* made carefully up a story/ran quickly up a hill).

6. Is it true that the particle cannot be moved away by topicalization (ie theme)?

(\* Up the story he made/Up the hill he ran)

7. Does the verbal combination passivize?

(The story was made up/\*The hill was run up)

8. Is nuclear stress on the particle in neutral intonation?

(The story which he made up/\*The hill which he ran up)

These tests do not work occasionally for all the verbs which seem to be phrasal: see about', for example, works well with tests 1, 4, 5, 6 and fails in the other tests. It is inconsistent, therefore, in four tests, Three tests, namely 2, 3. and 5, apparently do not work smoothly with the non-phrasal verb (ie prepositional verb) '*look after*'. The tests seem to be consistent with the phrasal verb

---

(15) The transformation that relates these constructions moves the particle word to the other side of the object of the VP.

---

'turn down' (an offer) and with the non-phrasal verb turn down (alone). Thus, the battery of tests unfortunately does not work consistently into patterning verbs into phrasal and non-phrasal. Between phrasal and non-phrasal verbs there seem to lie degrees of both categories. The test of 'passivization' is not a reliable test.<sup>(16)</sup> Moreover a tick (√) in 2 always means a tick in three. The same thing goes for a cross (x).

A good test, however, is that of 'preposition shift'. The prepositional particle may be shifted or preposed to the front of the sentence when a question is asked:

(46) Up what did he run?

(47) \* Up what did he make?

This question-form test occurs with phrasal verbs in terms of how, where, when, etc..... In Transformational Grammar (TG) the sentences:

(48) He made up a story.

(49) He ran up a hill.

would be analyzed as (50) and (51):

---

(16) On a more universal level what adds to the awkwardness of passivization as a test is that 'the existence of languages' whose active clause elements order is the same as that of the corresponding' passive shows that notions of the word order preposing, etc....., are not only inadequate as the basis of a universal characterization of passivization, but that they are hopeless for stating passivization internal to the grammars of particular languages'. Perlmutter, p. 25

(50)

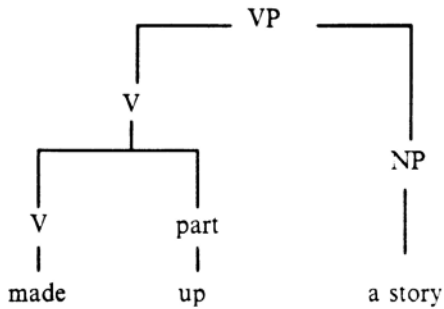

(51)

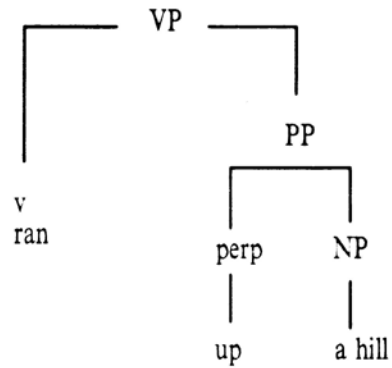

This may suggest that the distinction between phrasal verbs and prepositional ones is a distinction between  $v + \text{adv}$  syntactically functioning as a single unit and  $v + \text{preposition}$  each component syntactically functioning on its own.

A rule called ‘particle movement’ applies for the phrasal verb:  $V + \text{Part.} + \text{NP} \text{ \_\_\_\_ } V + \text{NP} + \text{Part.}$

$\text{made} + \text{up} + \text{a story} \text{ \_\_\_\_ } \text{made} + \text{a story} + \text{up}$

The rule is optional, but it is obligatory if the NP is an object pronoun (e. g. He made it up). The rule applies to adverbial particles ( $V + \text{Adv. particle} + \text{NP} \text{ \_\_\_\_ } V + \text{NP} + \text{Adv. particle}$ ). Thus, He looked ‘after’ the patient cannot be changed to He looked the patient after because in ‘make up’ and ‘order... about’. In ‘came in’ and ‘look after’, we have prepositional particles.

To distinguish between minimal sets of  $(v + \text{adv})$  and

---

phrasal verb, we may use the test of topicalisation:

(52) The boy ran up.

(53) Up ran the boy.

(54) The petrol gave out.

(55) \*Out gave the petrol.

Another test is that of the occurrence of the particle before a simple object NP, ie an object without modifiers. Thus, 'pulled up' in sentence (56):

(56) He pulled up the rope.

is a phrasal verb but 'pulled upwards' in (57) below is a v + Adv structure:

(57) He pulled upwards the rope.

Now can we express the tests already mentioned in terms of regularities? In Transformational Grammar, there is an underlying distinction between a 'phrasal verb' and a verb + a prepositional phrase.

## PHRASAL VERB

(made up a story)

1. In phrase structure grammar we will have a rule that regards the phrasal verb as a single item VP

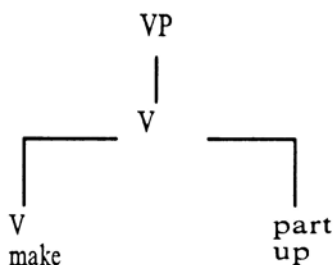

2. Passivization is possible but the passive rule is not enough to distinguish between phrasal and non-phrasal structures
3. There is no major constituent break to allow the insertion of an adverb
4. Topicalization does not work with phrasal verb:  
(\*Up the story he made) because 'up' does not make a separate constituent.
5. Particle movement rule applies for phrasal verbs:  
V + Particle + NP \_\_\_\_\_  
V + NP + Part. (optional, but obligatory if the NP is an object pronoun.

## V + PREP. PHRASE

(run up the hill)

1. 'Up' in lexicon will be under prep. and 'v' under subclass of verbs. The items occur as separate ones.

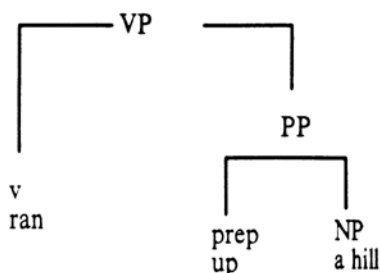

2. The 'passive rule' does not apply.
3. There is a major const. break between V and PP to allow the insertion
4. Topicalization works  
With non- phrasal. verbs:  
Up the hill he ran,  
because 'up' is a separate constituent.  
Particle movement rule cannot apply.

---

### ***III. DEGREES OF IDIOMATICITY***

Idiomacity with phrasal and non-phrasal verbs is a matter of degree. Thus, a phrasal verb like 'TURN DOWN' (an offer) is fully idiomatic in the sense that it passes all the tests mentioned. SEE ABOUT has a lower degree of idiomaticity in the sense of failing four out of eight tests. In other words, it has more transparent meaning than TURN DOWN (an offer, a proposal, etc...) though both suggest the notion of a positive final result. Thus, when we apply the eight tests which have to be answered by 'yes,' to 'turn down' (a proposal) we will have:

(58) She turned down his proposal (=refused to consider: a semantic unit)

(59) She turned his proposal down.

(60) She turned it up.

(61) \*The proposal down wich she turned.

(62) \*She turned carefully down his proposal.

(63) \*Down she turned his proposal.

(64) His proposal was turned down.

(65) The proposal which he turned down.

With SEE ABOUT, we will have:

(66) He saw about the matter (dealt with: a semantic unit)

(67) \*He saw the matter about.

(68) \*He saw it about.

(69) The matter about which he saw.



---

(70) He saw carefully about the matter.

(71) \*About he saw the matter.

(72) The matter was seen about.

(73) \*The matter which he saw about.

On the other hand, the lowest degree of idiomaticity obtains with the non-phrasal verb **TURN DOWN** (a lane) in the sense that it consistently fails the eight tests already mentioned:

(74) She turned down the lane (a non-semantic unit)

(75) \*She turned the lane down.

(76) \*She turned it down.

(77) The lane down which she turned.

(78) She turned carefully down the lane.

(79) Down she turned the lane. (A level of ambiguity obtains with this sentence).

(80) \* The lane was turned down.

(81) \*The lane which she turned down.

Degrees of idiomaticity are also seen with a prepositional verb like **BREAK INTO** (ie force one's way into a building, etc...). The following sentences suggest varying degrees of idiomaticity with the verb:

(82) The burglars broke into the bank.

(83) The anemic child broke into a rash. (suddenly had measles)

(84) The rider broke into a trot. (ie changed his movement)

---

suddenly)

Two tests, 'separation' and 'passivization', may isolate the less transparent from the most transparent prepositional verbs. The first test makes use of a relative clause. When applied to the sentences above, the test of separation seems to work smoothly with the first sense of **BREAK INTO**, thus setting it apart as the most transparent (ie the least idiomatic) of the three prepositional verbs:

(85) The bank into which the burglars broke.

(86) \*The rash into which the anemic child broke.

(87) \*The trot into which the rider broke.

Similarly, the test of 'passivization' which works smoothly with the first sense of **BREAK INTO** also isolates it as the most transparent prepositional verb:

(88) The bank was broken into.

(89) \*A rash was broken into.

(90) \*A trot was broken into.

The tests of 'separability' and 'passivization' also show that **PLY WITH** (ie keep sb. constantly supplied with) is less idiomatic than **TAKE FOR**:

#### PLY WITH

(91) I plied my guest with fruit.

(92) The guests whom I plied with fruit.

---

(93) The guests were plied with fruit.

TAKE FOR (ie suppose, conclude etc....):

(94) The man they took me for.

(95) \*The man for whom they took me.

(96) I was taken for the man they helped.

This clearly shows that the test of 'passivization' is NOT a reliable test.

#### *IV. CONCLUSIONS*

To recapture things, the paper has substantiated the particle in a phrasal verb as an adverb (e. g, catch on, touch down), thus specifying that which may be taken as a neutral designation for an overlapping item. In contrast, it has realized the particle going with prepositional verbs as a preposition (e. g. care for, approve of) and the particles in phrasal-prepositional verbs respectively as an adverb and a preposition (e. g. put up with, get away with). From a pedagogical angle, this is useful in the sense that the teacher would benefit by alerting his students, attention to this syntactic reality. A further pedagogical value is that the study alerts simultaneously teachers and learners to the idea that some dictionaries and some grammar books<sup>(17)</sup> address themselves to semantic equivalents, thus blurring out the distinction between phrasal verbs and other combinations of verbs plus particles.

---

(17) Johnson and Thornley's book; Grammar and Idiom, for example.

---

The paper has suggested that two common types of phrasal verbs obtain, an intransitive type and a transitive one. The intransitive type seems to relate to the transitive one in the senses of understood object, of active form and transitivity (e. g. The bridge blew up, He blew up the bridge). The eight tests provided by the study have decided whether a combination of a verb plus a particle is a phrasal verb or not. They have also been used to punctuate the degree of idiomaticity attained by phrasal verbs. Certain verbs seem to be in the process of becoming phrasal verbs (e. g. run over: He ran over the child), hence, the syntactic of a gradual process of ascending a higher degree of idiomaticity.

The paper has enunciated that a criterion for distinguishing prepositional verbs from free combinations of verb + preposition (e. g. call on vs. call after) is the possibility of making the prepositional object the subject of a correspondent passive clause:

*I called on the doctor. She called after dinner: The doctor was called on.*

*\*Dinner was called afer.*

The paper has also shown that the tests of 'separation' and 'passivization' validate that which distinguishes transparent prepositional verbs from less transparent ones, which may safely be called 'marginal' phrasal verbs. This only means that between phrasal and non-phrasal verbs there is a hazy area and some verbs appear to be more of one category than another. However, we have cases where are verbs (e. g. 'enjoy', 'sack') which do not occur in phrasal groups and there are others that only occur in phrasal combinations (e. g. 'peter', 'cave': *The*

---

*supplies petered out* (ie. they gradually came to an end). *The roof of the tunnel caved in* (ie fell in, gave way to pressure).

The study has also touched on the phrasal - prepositional verbs which realize combinations of verb plus two particles, the first an adverb, the second a preposition (e. g. got away with). The paper has suggested that there are also some combinations of three-element words that fail to fit the description of categorically phrasal verb, prepositional verb and phrasal-prepositional verb though they have certain idiomatic features that correspond to the verbs (e. g. put paid to, ie. settle). Passivization seems to work smoothly with the three-element verb as a whole (They soon put paid to the proposal. The question was soon put paid to).

These concluding insights elegantly seem to show that the study usefully alerts us to the complexity of syntactic issues and to the assumption that grammatical categories must be based on available formal evidence to evade potential confusion.

---

## BIBLIOGRAPHY

- Fabb, Nigel. 1994. **Sentence structure**. New York: Routledge.
- Freeborn, Dennis. 1993. **A Course Book: English Grammar**. London: Macmillan.
- Greenbaum, Sidney and Randolph Quirk. 1991. **A Student's Grammar of the English Language**. United Kingdom: Longman.
- Johnson, A. and G. C. Thornley. 1961. **Grammar and Idiom**. London: Longman
- Perlmutter, David M. (ed.) 1986. **Studies in Relational Grammar**. (vol. 1). Chicago: The University of Chicago Press.
- Palmer, F. R. 1987. **The English Verb**. London: Longman.
- Quirk, R. et. al. 1992. **A Comprehensive Grammar of the English Language**. New York: Longman.
- Svartvik, Jan. 1966. **On voice in the English Verb**. The Hague: Mouton and Co.
- Takami, Ken-ichi. 1992. **Preposition stranding: from syntactic to functional analyses**. Berlin: Mouton de Gruyter.
- Wekker, H. and L. Haegeman. 1985. **A Modern course in English syntax**. London: Croom Helm.